



- 목 차 -

1. SPECIFICATIONS .....	2
2. BLOCK DIAGRAM .....	3
3. LAYOUT .....	4
4. INSTALLATION & DESCRIPTION .....	5
4.1 JUMPER INSTALLATION .....	5
4.1.1 BATTERY SELECTABLE CONNECTOR [CCMOS1].....	5
4.1.2 LCD PANEL VOLTAGE SELECTABLE CONNECTOR [LVDS2] (Option).....	5
4.2 CONNECTOR DESCRIPTION .....	5
4.2.1 ATX POWER CONNECTION [AXTPWR1, ATXPWR2].....	5
4.2.2 POWER, RESET S/W CONNECTOR [FPI01].....	6
4.2.3 FAN CONNECTION [CPUFAN1, AUXFAN1] .....	6
4.2.4 SERIAL CONNECTOR [COM1, COM2~COM4].....	6
4.2.5 VGA CONNECTOR [VGA1] .....	7
4.2.6 KEYBOARD/MOUSE CONNECTOR [KM1] .....	7
4.2.7 PARALLEL1 CONNECTOR [LPT1] .....	7
4.2.8 UNIVERSAL SERIAL BUS CONNECTOR [USB2].....	7
4.2.9 LAN+USB CONNECTOR [U11, USB1] .....	8
4.2.10 AUDIO CONNECTOR [AUD2, AUD1] .....	8
4.2.11 DIGITAL I/O INTERFACE CONNECTOR [DI01].....	8
4.2.12 LVDS PANEL BACKLIGHT VOLTAGE SELECT [W1] (Option).....	9
4.2.13 LVDS INTERFACE CONNECTOR [LVDS1] (Option).....	9
4.2.14 SATA INTERFACE CONNECTOR [SATA1, SATA2, SATA3, SATA4].....	9
4.2.15 IDE INTERFACE CONNECTOR [IDE1] .....	10
4.2.16 PCI INTERFACE CONNECTOR [PCI3,PCI4].....	11
4.2.17 PCI EXPRESS INTERFACE CONNECTOR [PCIE2(A1~A32B1~B32),PCIEXP1] .....	11
5. MEASUREMENT DRAWING .....	13
6. REFERENCE .....	13



## 1. SPECIFICATIONS

Spec	Description
Processor	Intel Core2 Duo, Intel Pentium-D, Celeron-D 341 and 352, Pentium 4 651 and 551, LGA775 Package
Main Chipset	Intel 945G, 1066MT/s FSB, Memory Controller upto DDR2 667, GMA 950 Graphics controller using Core Frequency 400MHz, CRT Port, PCI-e x16 Graphics Port multiplexed with 2 SDVO port for LVDS/TV/DVI, DMI interface with ICH7R, 34mm x 34mm, 1202 FCBGA Package
Main Chipset	Intel ICH7, 4 PCI-e interface, 6 PCI interface, LPC interface, 4 SATA II 3Gb/s interface, 1 PATA IDE interface, 8 USB 2.0 ports, 31mm x 31mm 652 mBGA Package
Graphics	GMA950, Integrated 2D/3D Graphics Controller in 945G, Dynamic Frame Buffer size on System Memory, max 224MB
Memory	2 240 pin DDR2 DIMM Socket [Support upto DDR2 667, upto 4GB]
Ethernet	1 10/100M/1G Ethernet Ports [RJ45], VT6130 Ethernet Controller
Super I/O	W83627HG, Winbond, Super I/O with 2 Serial Ports, LPC interface
Super I/O	PS/2 bus K/B, Mouse Port 지원, 2 Serial Port [COM1,2] 지원
Super I/O	1x Parallel Port, 1x LPC-To-UART F81216D (COM3, 4) 지원
Audio	1 x HDC
IDE	Primary, UDMA 66, 100 IDE interface
IDE	Support 1 PATA / 4 SATA II interface for 3 Gb/s
Expansion	2 x PCI Slot, 1 x PCI Multi Extension Port (Option)
Expansion	1 x PCI-Express 16X Port, 1 x PCI-express 4X Port
Back Panel I/O	1 x CRT Port, 1 x Serial ports, COM1, 1 x Parallel ports, LPT1
Back Panel I/O	1 x Ethernet port (1Gbps)+ 2 x USB 2.0/1.1 ports, 2 x USB 2.0/1.1 ports
Back Panel I/O	1 x Audio Jack, Line out, Mic, Line in
Back Panel I/O	1 x PS2 K/B, Mouse Port
On Board I/O Connectors	1 x 40 pin Box Header, IDE Connector
On Board I/O Connectors	4 x 8 pin Straight connector, 4 x SATA Ports
On Board I/O Connectors	2 x 4 pin Header, 2 USB ports
On Board I/O Connectors	2 x 10 pin Header, 3 x Serial Port ( COM 2, 3, 4)
On Board I/O Connectors	2 x 3 pin Fan connector, CPU + System, 1 x 3 pin Header, CMOS Clear
On Board I/O Connectors	1 x 3 pin LVDS Vdd/2 x 20 LVDS connector/1 x 6 Backlight Voltage Select (Option)
BIOS	Phoenix/Award BIOS
Power	24 Pin + 4 pin ATX
Form Factor	mATX Form Factor, size 244mm x 244mm, 4 Layers
Operating Temp	0 to 60 C

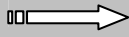

## 2. BLOCK DIAGRAM

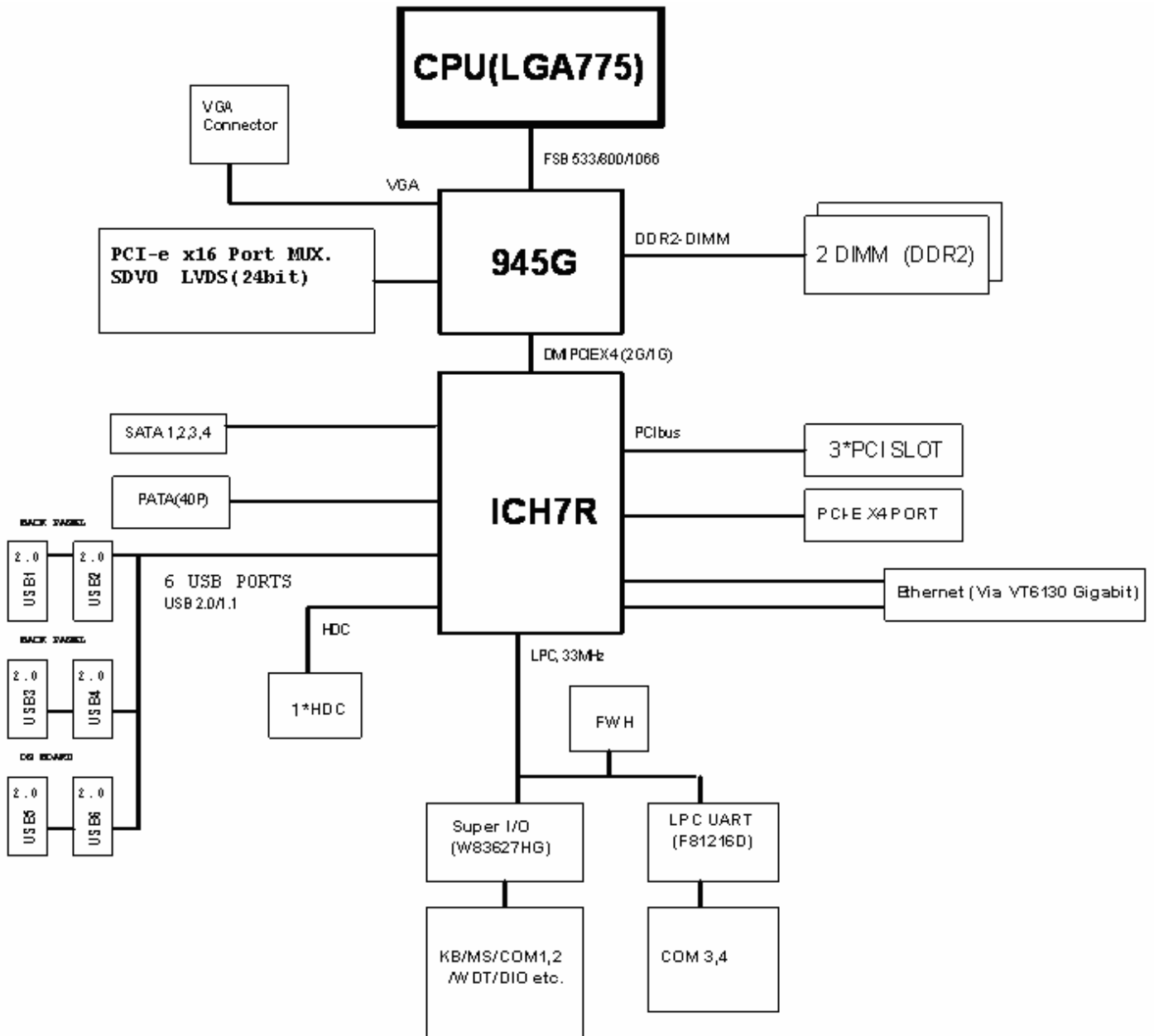



### 3. LAYOUT

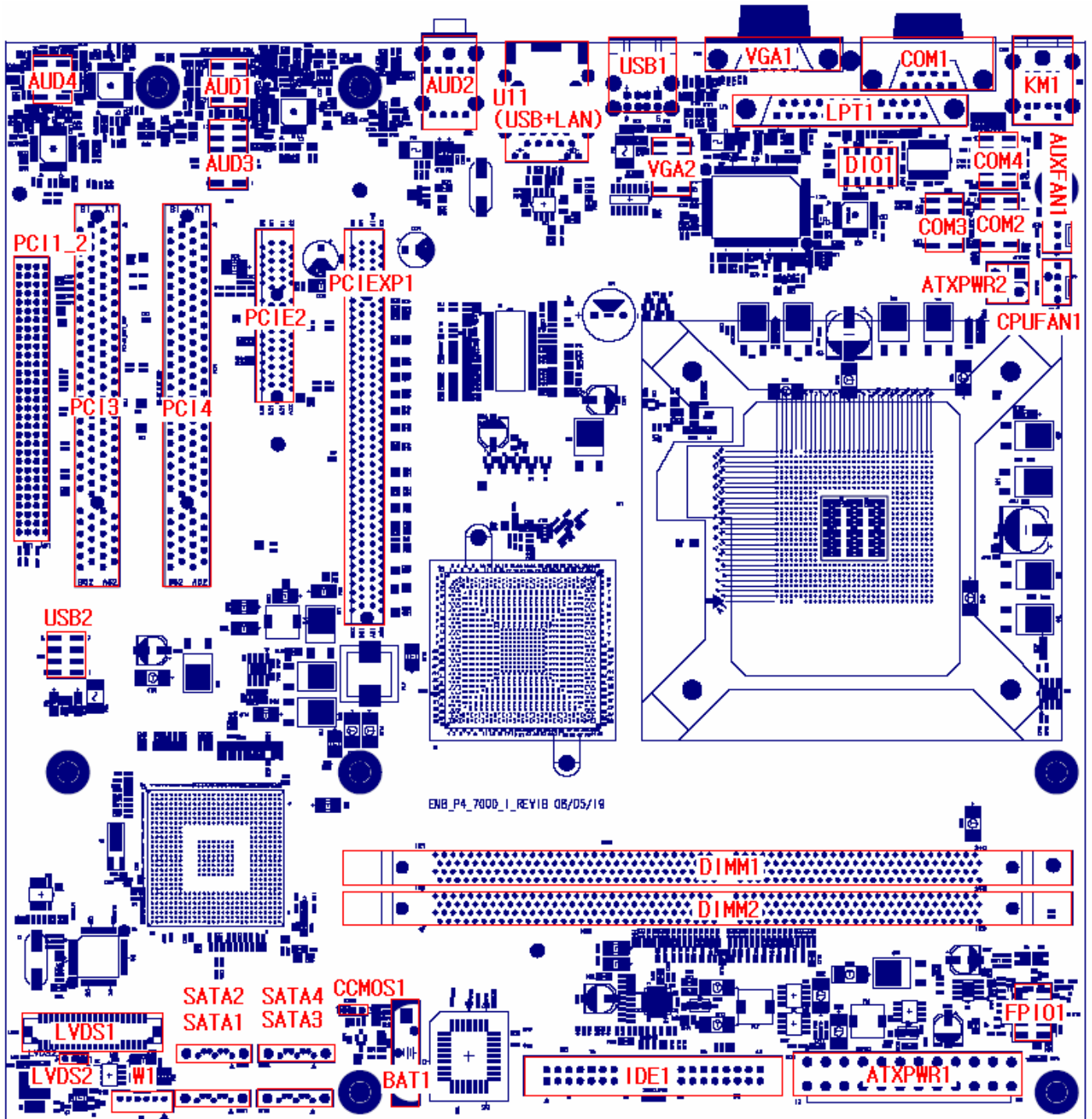



## 4. INSTALLATION & DESCRIPTION

### 4.1 JUMPER INSTALLATION

#### 4.1.1 BATTERY SELECTABLE CONNECTOR [CCMOS1]

PIN	SIGNAL	DESCRIPTION
1	IBAT	ON-BOARD Battery used (1-2)
2	VBATT	External or Internal Battery Common pin
3	GND	CMOS Clear (2-3)

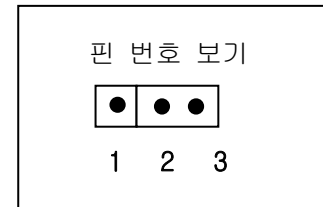

#### 4.1.2 LCD PANEL VOLTAGE SELECTABLE CONNECTOR [LVDS2] (Option)

PIN	SIGNAL	DESCRIPTION
1-2	VCC3	LCD PANEL 3V
2-3	VCC5	LCD PANEL 5V

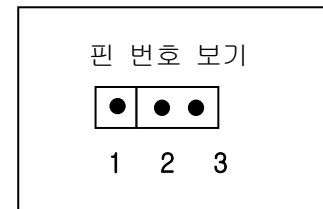

### 4.2 CONNECTOR DESCRIPTION

#### 4.2.1 ATX POWER CONNECTION [AXTPWR1, ATXPWR2]

ATXPWR1		ATXPWR2	
24-pin Power Supply Connector			
+3.3V		+3.3V	
-12V		+3.3V	
COM		COM	
PS_ON		+5v	
COM		COM	
COM		+5V	
COM		COM	
Reserved		PWR_OK	
+5V		5VSB	
+5V		+12V	
+5V		+12V	
COM		3.3V	
4-pin Power Supply Connector			
+12V		COM	
+12V		COM	

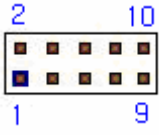

### 4.2.2 POWER, RESET SW CONNECTOR [FPIO1]

	PIN	SIGNAL	PIN	SIGNAL
	1	PWR_LED	2	GND
	3	HD_LED	4	HD_LED#
	5	STANDBY_LED	6	STANDBY_LED#
	7	PSON_SW	8	PSON#
	9	RST_SW	10	GND

### 4.2.3 FAN CONNECTION [CPUFAN1, AUXFAN1]

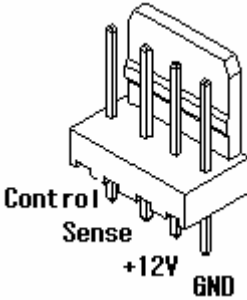
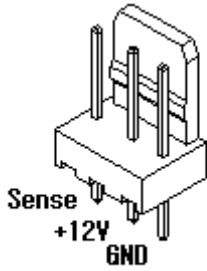
CPUFAN1	AUXFAN1
	

### 4.2.4 SERIAL CONNECTOR [COM1, COM2~COM4]

COM1	PIN	COM2~COM4
DCD(Data Carrier Detect)	1	DCD(Data Carrier Detect)
SIN(Serial Input)	2	SIN(Serial Input)
SOUT(Serial Output)	3	SOUT(Serial Output)
DTR(Data Terminal Ready)	4	DTR(Data Terminal Ready)
GND	5	GND
DSR(Data Set Ready)	6	DSR(Data Set Ready)
RTS(Request To Send)	7	RTS(Request To Send)
CTS(Clear To Send)	8	CTS(Clear To Send)
RI(Ring Indicator)	9	RI(Ring Indicator)
	10	NC

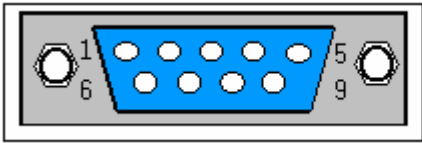

**SERIAL**

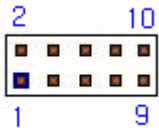

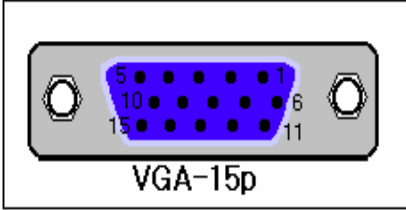

#### 4.2.5 VGA CONNECTOR [VGA1]

 <p>VGA-15p</p>	SIGNAL	PIN	PIN	SIGNAL
	Red	1	9	+5V
	Green	2	10	GND
	Blue	3	11	NC
	NC	4	12	I2C Clk
	GND	5	13	H-sync
	Frame GND	6	14	V-Sync
	Frame GND	7	15	I2C Data
	Frame GND	8		

#### 4.2.6 KEYBOARD/MOUSE CONNECTOR [KM1]

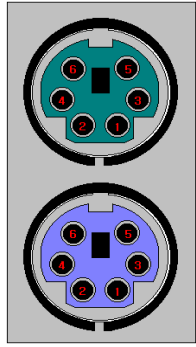
	PIN	KEYBOARD	MOUSE
	1	KEYBOARD DATA	MOUSE DATA
	2	NC	NC
	3	GND	GND
	4	+5V	+5V
	5	KEYBOARD CLOCK	MOUSE CLOCK
	6	NC	NC

#### 4.2.7 PARALLEL1 CONNECTOR [LPT1]

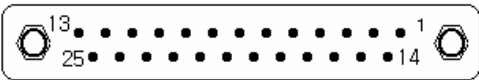
	SIGNAL	PIN	PIN	SIGNAL
	STB-	1	2	D0
	D1	3	4	D2
	D3	5	6	D4
	D5	7	8	D6
	D7	9	10	ACK-
	BUSY	11	12	PE
	SLCT	13	14	AFD-
	ERR-	15	16	INIT-
	SL IN-	17	18	GND
	GND		19~25	GND

#### 4.2.8 UNIVERSAL SERIAL BUS CONNECTOR [USB2]

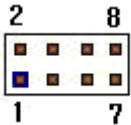
 <p>USB2</p>	PIN	SIGNAL	PIN	SIGNAL
	1	USB PORT VCC	2	USB PORT VCC
	3	USB0 D-	4	USB1 D-
	5	USB0 D+	6	USB1 D+
	7	GND	8	GND

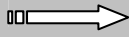

#### 4.2.9 LAN+USB CONNECTOR [U11, USB1]

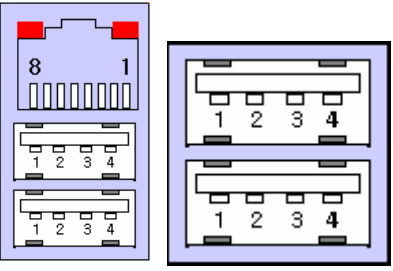
USB	PIN	LAN
USBVCC	1	TX+
DATA-	2	TX-
DATA+	3	RX+
USBGND	4	NC
	5	NC
	6	RX-
	7	NC
	8	NC

#### 4.2.10 AUDIO CONNECTOR [AUD2, AUD1]

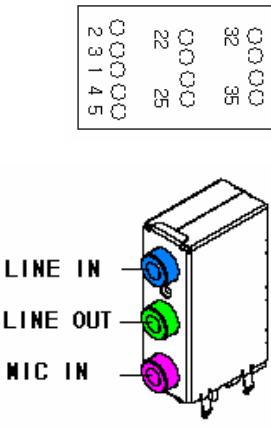
AUD2	LINE OUT		LINE IN		MIC IN	
	PIN	SIGNAL	PIN	SIGNAL	PIN	SIGNAL
	1	AGND	22	FRONT_L	32	MIC REF
	2	LINE IN L	23	NC	33	NC
	3	NC	24	NC	34	NC
	4	NC	25	FRONT_R	35	MIC IN
	5	LINE IN R				

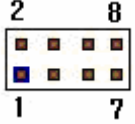
AUD1	PIN	SIGNAL	PIN	SIGNAL
	1	REAR_L	2	REAR_R
	3	GND	4	GND
	5	SURR_JD	6	CEN_JD
	7	LFEOUT	8	CENTOUT

#### 4.2.11 DIGITAL I/O INTERFACE CONNECTOR [DIO1]

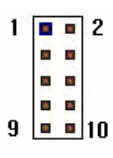
	DESCRIPTION	SIGNAL	PIN	PIN	SIGNAL	DESCRIPTION
	General purpose I/O	GP1010	1	2	GP1011	General purpose I/O
	General purpose I/O	GP1012	3	4	GP1013	General purpose I/O
	General purpose I/O	GP1014	5	6	GP1015	General purpose I/O
	General purpose I/O	GP1016	7	8	GP1017	General purpose I/O
	+5V POWER	+5V	9	10	GND	GND



**4.2.12 LVDS PANEL BACKLIGHT VOLTAGE SELECT [W1] (Option)**

PIN	SIGNAL
1	BACKLIGHT VOLTAGE
2	+5V
3	+3V
4	ENABLE BACKLIGHT
5	GND
6	GND

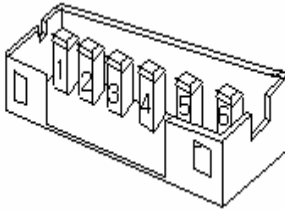

**4.2.13 LVDS INTERFACE CONNECTOR [LVDS1] (Option)**

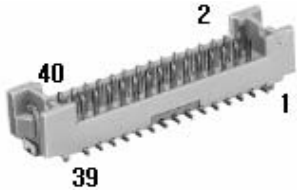

SIGNAL	PIN	PIN	SIGNAL
VCC_LCD	2	1	VCC_LCD
VCC_LCD	4	3	VCC_LCD
GND	6	5	GND
A0M	8	7	A4M
A0P	10	9	A4P
GND	12	11	GND
A1M	14	13	A5M
A1P	16	15	A5P
GND	18	17	GND
A2M	20	19	A6M
A2P	22	21	A6P
GND	24	23	GND
CLK1M	26	25	CLK2M
CLK1P	28	27	CLK2P
GND	30	29	GND
SD DDC	32	31	SC DDC
GND	34	33	GND
A3M	36	35	A7M
A3P	38	37	A7P
GND	40	39	GND

**4.2.14 SATA INTERFACE CONNECTOR [SATA1, SATA2, SATA3, SATA4]**

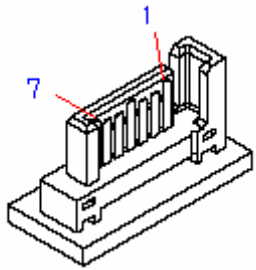

PIN	SATA1	SATA2
1	GND1	GND1
2	ICH_STAT_TXP0	ICH_SATA_TXP1
3	ICH_SATA_TXN0	ICH_SATA_TXN1
4	GND2	GND2
5	ICH_SATA_RXN0	ICH_SATA_RXN1
6	ICH_STAT_RXP0	ICH_SATA_RXP1
7	GND3	GND3



#### 4.2.15 IDE INTERFACE CONNECTOR [IDE1]

PIN	SIGNAL	Description
1	IDEPRSTX	Reset signal to the hard disk
2,22,24,26, 28,30,32,40	GND	Hard Disk GND
3	IDEPDR7	Low part of data bus
4	IDEPDR8	High part of data bus
5	IDEPDR6	Low part of data bus
6	IDEPDR9	High part of data bus
7	IDEPDR5	Low part of data bus
8	IDEPDR10	High part of data bus
9	IDEPDR4	Low part of data bus
10	IDEPDR11	High part of data bus
11	IDEPDR3	Low part of data bus
12	IDEPDR12	High part of data bus
13	IDEPDR2	Low part of data bus
14	IDEPDR13	High part of data bus
15	IDEPDR1	Low part of data bus
16	IDEPDR14	High part of data bus
17	IDEPDR0	Low part of data bus
18	IDEPDR15	High part of data bus
19	GND	Hard Disk GND
20	NC	Not Connected
21	IDEPDREQR	Disk DMA Request might be driven by the IDE hard disk to request bus master access to the PCI bus
23	IDEPIOWX	I/O Write
25	IDEPIORX	I/O Read
27	IDEPIORDYR	This signal may be driven by the hard disk to extend the current I/O cycle
29	IDEPDACKX	Disk DMA Acknowledge
31	IDEPINTR	Interrupt line from hard disk
33	IDEPA1	Address line, used to address i/o registers in the IDE hard disk
34	NC	Not Connected
35,36	IDEPA0,2	Address line, used to address i/o registers in the IDE hard disk
37	IDEPCS0X	Hard Disk Chip-Select
38	IDEPCS1X	Hard Disk Chip-Select
39	HDDLED	Signal from hard disk indicating hard disk activity



#### 4.2.16 PCI INTERFACE CONNECTOR [PCI3,PCI4]

PIN	SIGNAL	PIN	SIGNAL	PIN	SIGNAL	PIN	SIGNAL
A1	NC	A2	+12V	B1	-12V	B2	NC
A3	NC	A4	NC	B2	GND	B4	NC
A5	+5V	A6	INT_B	B5	+5V	B6	+5V
A7	INT_D	A8	+5V	B7	INT_C	B8	INT_A
A9	NC(IDSEL1)	A10	+5V	B9	PRSTN_11	B10	NC(PCICLK1)
A11	NC(GNT1)	A12	GND	B11	PRSNT_12	B12	GND
A13	GND	A14	+3.3V	B13	GND	B14	NC(REQ1)
A15	PCIRST	A16	+5V	B15	GND	B16	PCICLK0
A17	PGNT_0	A18	GND	B17	GND	B18	PREQ_0
A19	NC	A20	AD30	B19	+5V	B20	AD31
A21	+3.3V	A22	AD28	B21	AD29	B22	GND
A23	AD26	A24	GND	B23	AD27	B24	AD25
A25	AD24	A26	AD18	B25	+3.3V	B26	C_BE_3
A27	+3.3V	A28	AD22	B27	AD23	B28	GND
A29	AD20	A30	GND	B29	AD21	B30	AD19
A31	AD18	A32	AD16	B31	+3.3V	B32	AD17
A33	+3.3V	A34	FRAME_	B33	C_BE_2	B34	GND
A35	GND	A36	TRDY_	B35	IRDY_	B36	+3.3V
A37	GND	A38	STOP_	B37	DEVSEL_	B38	GND
A39	+3.3V	A40	+5V	B39	PLOCK_	B40	PERR_
A41	+5V	A42	GND	B41	+3.3V	B42	SERR_
A43	PAR	A44	AD15	B43	+3.3V	B44	C_BE_1
A45	+3.3V	A46	AD13	B45	AD14	B46	GND
A47	AD11	A48	GND	B47	AD12	B48	AD10
A49	AD9	A50	GND	B49	GND	B50	GND
A51	GND	A52	C_BE_0	B51	GND	B52	AD8
A53	+3.3V	A54	AD6	B53	AD7	B54	+3.3V
A55	AD4	A56	GND	B55	AD5	B56	AD3
A57	AD2	A58	AD0	B57	GND	B58	AD1
A59	+5V	A60	PREQ64_1	B59	+5V	B60	PACK64_1
A61	+5V	A62	+5V	B61	+5V	B62	+5V

#### 4.2.17 PCI EXPRESS INTERFACE CONNECTOR [PCIE2(A1~A32B1~B32),PCIEXP1]

PIN	SIGNAL	PIN	SIGNAL	PIN	SIGNAL	PIN	SIGNAL
A1	PRSNT1#	A2	12V	B1	12V	B2	12V
A3	12V	A4	GND	B2	12V	B4	GND



A5	JTAG	A6	JTAG	B5	SMCLK	B6	SMDAT
A7	JTAG	A8	JTAG	B7	GND	B8	3.3V
A9	3.3V	A10	3.3V	B9	JTAG	B10	3.3VAUX
A11	PWRGD	A12	GND	B11	WAKE*	B12	RSVD
A13	REFCLK+	A14	REFCLK-	B13	GND	B14	HSOP0
A15	GND	A16	HSIP0	B15	HSOP0	B16	GND
A17	HSIN0	A18	GND	B17	PRSENT2#_1	B18	GND
A19	RSVD	A20	GND	B19	HSOP1	B20	HSOP1
A21	HSIP1	A22	HSIN1	B21	GND	B22	GND
A23	GND	A24	GND	B23	HSOP2	B24	HSOP2
A25	HSIP2	A26	HSIN2	B25	GND	B26	GND
A27	GND	A28	GND	B27	HSOP3	B28	HSOP3
A29	HSIP3	A30	HSIN3	B29	GND	B30	RSVD
A31	GND	A32	RSVD	B31	PRSENT2#_2	B32	GND
A33	RSVD	A34	GND	B33	HSOP4	B34	HSOP4
A35	HSIP4	A36	HSIN4	B35	GND	B36	GND
A37	GND	A38	GND	B37	HSOP5	B38	HSOP5
A39	HSIP5	A40	HSIN5	B39	GND	B40	GND
A41	GND	A42	GND	B41	HSOP6	B42	HSOP6
A43	HSIP6	A44	HSIN6	B43	GND	B44	GND
A45	GND	A46	GND	B45	HSOP7	B46	HSOP7
A47	HSIP7	A48	HSIN7	B47	GND	B48	PRSENT2#_3
A49	GND	A50	RSVD	B49	GND	B50	HSOP8
A51	GND	A52	HSIP8	B51	HSOP8	B52	GND
A53	HSIN8	A54	GND	B53	GND	B54	HSOP9
A55	GND	A56	HSIP9	B55	HSOP9	B56	GND
A57	HSIN9	A58	GND	B57	GND	B58	HSOP10
A59	GND	A60	HSIP10	B59	HSOP10	B60	GND
A61	HSIN10	A62	GND	B61	GND	B62	HSOP11
A63	GND	A64	HSIP11	B63	HSOP11	B64	GND
A65	HSIN11	A66	GND	B65	GND	B66	HSOP12
A67	GND	A68	HSIP12	B67	HSOP12	B68	GND
A69	HSIN12	A70	GND	B69	GND	B70	HSOP13
A71	GND	A72	HSIP13	B71	HSOP13	B72	GND
A73	HSIN13	A74	GND	B73	GND	B74	HSOP14
A75	GND	A76	HSIP14	B75	HSOP14	B76	GND
A77	HSIN14	A78	GND	B77	GND	B78	HSOP15
A79	GND	A80	HSIP15	B79	HSOP15	B80	GND
A81	HSIN15	A82	GND	B81	PRSENT2#_4	B82	RSVD

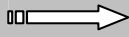

## 5. MEASUREMENT DRAWING

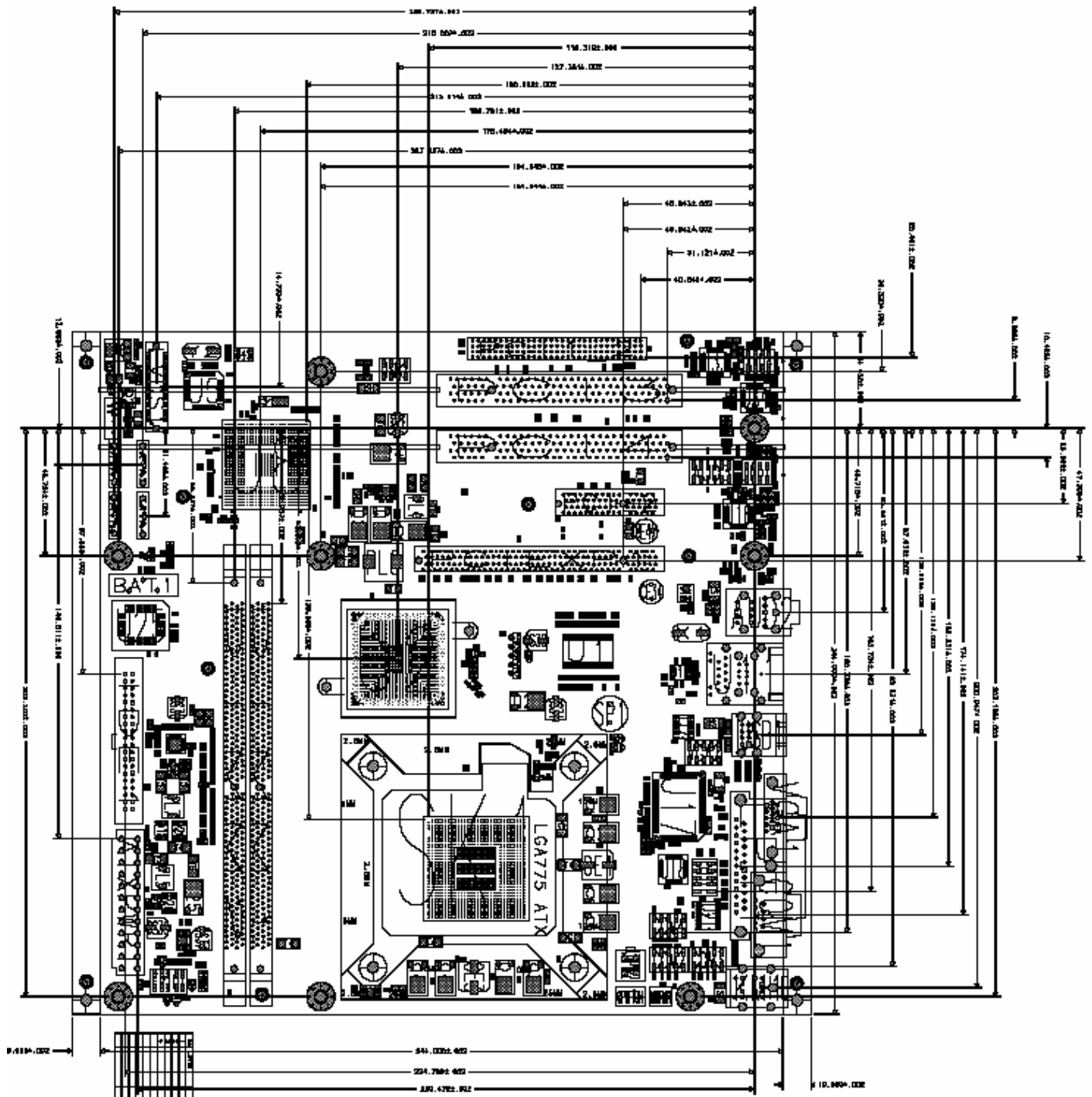

## 6. REFERENCE

- Technical Support — [gkdisan@syncus.co.kr](mailto:gkdisan@syncus.co.kr)
- Sales Support — [syncus@syncus.co.kr](mailto:syncus@syncus.co.kr)